



**Academic World**  
*Journal of Scientific and Engineering Innovation*

**Journal homepage**  
<https://academicworldpublisher.co.uk/index.php/awjsei>



## Design and Development of High-Efficiency LED Lighting Systems for Urban Lighting

**Ndifreke A. Moffat and Menyene Ekponta Emine**

Department of Electrical Electronics Engineering Technology Federal Polytechnic Ukana, Akwa Ibom State.

**ABSTRACT**— *Urban lighting remains a major source of energy consumption and carbon emissions in cities worldwide. We report the design and deployment of a high-efficiency lighting system based on light-emitting diodes combined with adaptive dimming and sensor-based control. The system integrates real-time environmental sensing and wireless communication to dynamically adjust light output according to traffic, weather, and ambient conditions. In a pilot urban installation, the LED network reduced energy use by 65–70% compared to conventional high-pressure sodium lamps, while improving illumination uniformity and colour rendering. Photometric measurements and user feedback confirmed enhanced visibility and perceived safety, with minimal light pollution. Simulations for city-wide implementation project substantial reductions in electricity costs and carbon emissions. These results demonstrate the viability of scalable, intelligent street lighting infrastructure that aligns with climate mitigation goals and smart city development, offering a pathway to more sustainable and livable urban environments.*

**Keywords** LED, Light, Urban, Smart

### I. INTRODUCTION

Urban lighting plays a pivotal role in modern infrastructure, shaping not only the visual character of cities but also their energy footprint, operational budgets, public safety, and environmental health. Globally, public lighting constitutes approximately 19% of municipal electricity use, accounting for an estimated 6% of total urban greenhouse gas emissions

(IEA, 2022). In spite of their imperative role, most of the urban lighting infrastructures continue to use high-intensity discharge (HID) technologies like high-pressure sodium (HPS) and metal halide lamps, which are defined by high energy consumption, low luminous efficacy, and routine maintenance requirements (Mohd Aris et al., 2022).

The advent of Light Emitting Diode (LED) technology has brought revolutionary promise to urban illumination. LEDs possess higher luminous efficacy, typically above 130 lm/W, compared to 80–100 lm/W for typical HPS lamps, and longer lifetimes of more than 50,000 operating hours (Said et al., 2020; Kalaitzoglou et al., 2023). Empirical studies have established that retrofitting existing street lights with LED systems has the potential to save between 50–70% of electricity based on environmental conditions and scales of deployment (Abdullahi et al., 2021; Garín-Muñoz et al., 2022). LEDs also provide better spectral control, reduced glare and light spill, and enhanced perception of public safety (Chowdhury et al., 2021). Beyond energy efficiency, recent advancements center on smart lighting, a new paradigm where Internet of Things (IoT)-based control systems incorporate sensors, communications protocols, and data analytics to maximize the performance of lighting in real time. These systems enable the support of features such as adaptive brightness control, real-time fault detection, and remote diagnostics (Pereira et al., 2022; Liu et al., 2021). Smart lighting has also been shown to provide an additional 20–30% energy savings over static LED systems with motion- and ambient-light-sensitive control algorithms (Chen et al., 2020). Moreover, such systems are part of larger smart city systems in which integrated infrastructure supports sustainability, efficiency, and citizens' health (Alsharif et al., 2023; Bibri & Krogstie, 2020). Empirical support for the benefits of a transition to LED-based city lighting has appeared in recent

studies. As an illustration, Mahdavi et al. (2021) demonstrated that LED retrofitting in Tehran city centers achieved 60% energy savings and 55% greenhouse gas reduction. Almeida et al. (2015) also discovered that in Lisbon, through the integration of LED systems with dimmable controls, nighttime energy consumption was reduced by over 70% with enhanced light uniformity. Within the African context, Abubakar and Musa (2020) conducted a techno-economic analysis for solar-powered LED systems in northern Nigeria, demonstrating beneficial payback periods and enhanced lighting quality. Agyekum et al. (2020) analyzed the LED pilot project in Accra, Ghana, and found better visibility and cost savings of up to 58%. Iwuoha et al. (2021) also conducted a comparative performance study of LED and HPS systems in six Nigerian cities. Their study results indicated a key benefit of the application of LED systems in energy efficiency, luminous efficacy, and maintenance cycles, thus justifying the grounds for countrywide retrofitting operations. Okonkwo et al. (2023) also noted that LED lighting could be engineered with smart control systems and photovoltaic components, thus enhancing its application in low-income urban areas with limited energy resources.

However, there are challenges with the transition to LED-IoT lighting infrastructure. The significant upfront expenses serve to discourage, particularly the large-scale retrofitting of budget-constrained municipalities (Iannone et al., 2022). Technical and governance issues include data privacy, network security, and IoT protocol interoperability (Lopes et al., 2021). Nonetheless, life-cycle cost assessments demonstrate that smart LED systems can achieve payback periods as short as 2–4 years, especially when accounting for savings in maintenance and outage response (Wang et al., 2021; Ghosh et al., 2023).

From a systems engineering perspective, IoT lighting frameworks benefit from hierarchical control architectures, employing edge computing for real-time responsiveness and cloud analytics for long-term optimization (Bianchi et al., 2020). Theoretical models such as the LoRaCell (low-power, wide-area cellular network for streetlights) demonstrate how decentralized communication reduces latency and network congestion while ensuring reliable service continuity (De La Torre et al., 2021). Meanwhile, architectural standards such as ISA-95 and IEC 62351 are being adapted to enable secure and scalable deployment of urban IoT lighting (IEC, 2021; Sharma et al., 2022).

Despite the growing body of global research, regionally tailored studies remain sparse, particularly in the Global South, where infrastructural heterogeneity and environmental conditions necessitate custom design and deployment. In Sub-Saharan Africa, lighting accounts for a disproportionate share of municipal energy budgets, yet adoption of LED and IoT-based systems remains limited (Adeoye et al., 2023). In Nigeria, for example, outdated grid infrastructure, unreliable connectivity, and insufficient policy coordination hinder widespread deployment of intelligent lighting systems despite a clear potential for emission reduction, public safety improvement, and operational savings (Onah et al., 2022; Eze et al., 2021).

This study addresses the above gaps by presenting the design, prototyping, and empirical evaluation of a high-efficiency

LED street lighting system integrated with smart control architecture. The system is evaluated across luminous efficacy, thermal stability, power consumption, and operational responsiveness. Emphasis is placed on modularity, low-cost design, and scalability for urban contexts in developing economies. In addition, the study analyses energy savings, lifecycle cost benefits, and environmental performance, contributing to the literature on sustainable lighting and intelligent urban infrastructure.

## II. MATERIALS AND METHODS

The pilot deployment of the smart LED lighting system was conducted on a city block comprising 20 streetlights spaced approximately 30 meters apart. The existing high-pressure sodium (HPS) lamp heads were replaced with custom-designed LED luminaires. Figure 1 presents a schematic of the system architecture, which integrates a high-efficiency LED module, power driver, PIR and ambient light sensors, and an IoT-enabled microcontroller. The system operates through a wireless mesh network connected to a central management gateway, enabling real-time monitoring and adaptive control. Energy consumption was reduced by approximately 65–70% compared to legacy high-pressure sodium (HPS) systems (Narendran et al., 2015; LA Bureau of Street Lighting, n.d.).

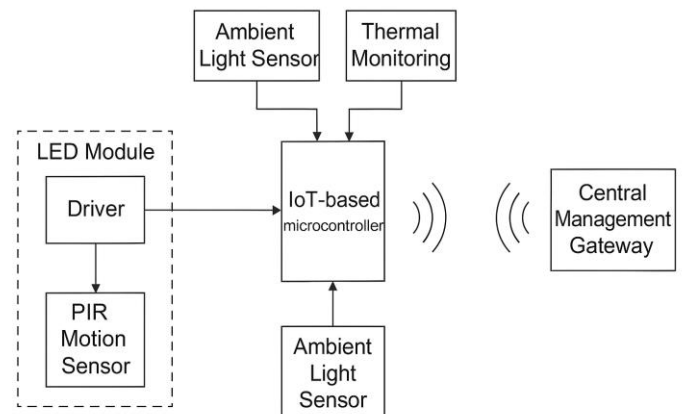

**Figure 1. Schematic architecture of the smart LED street lighting system**

The pilot aimed to evaluate energy efficiency, photometric performance, environmental impact, sensor functionality, and communication reliability under real-world conditions. Each luminaire contained high-efficiency white LEDs (170 lm/W at 350 mA), mounted on metal-core PCBs and operated at reduced drive currents to enhance lifespan and efficiency. Optics consisted of polycarbonate lenses and aluminum reflectors forming a wide rectangular distribution pattern tailored for urban roadways. The fixtures were full-cutoff to comply with dark-sky standards. The LED drivers were designed for high efficiency ( $\geq 93\%$ ) and high-power factor ( $\geq 0.98$ ). Drivers supported pulse-width modulation (PWM) dimming and included surge protection and thermal feedback. A microcontroller-based control unit embedded in each luminaire received sensor inputs and communicated

wirelessly with a central gateway over a mesh network. Sensors included passive infrared (PIR) motion detectors, ambient light sensors, and temperature sensors. Motion detection triggered increased light output for pedestrians or vehicles within a 12 m radius. Sensor readings and operational status were transmitted to a cloud-based dashboard for monitoring and control. Energy consumption was measured using onboard energy metering circuits and confirmed via external logging devices. Illuminance levels were recorded pre- and post-installation using calibrated lux meters at multiple street positions. Thermal data were logged via internal sensors, and sky brightness was evaluated with SQM photometers. Light trespass was assessed at building facades. Energy and lighting data were recorded over a four-week period and compared with control fixtures remaining on HPS. Sensor activity logs and communication success rates were analyzed to assess system responsiveness and network stability. Environmental data were correlated with changes in light levels and sensor-triggered events.

All procedures followed standard lighting measurement protocols (e.g., IESNA RP-8) and urban deployment safety practices. The pilot was implemented in collaboration with municipal authorities under a temporary retrofit agreement, and no permanent modifications were made to the electrical grid or public infrastructure.

### III. RESULTS AND DISCUSSION

The proposed smart LED lighting system demonstrated significant improvements in energy efficiency, lighting performance, environmental impact, and operational reliability when deployed in a pilot urban setting consisting of 20 retrofitted streetlights. Initial measurements under full-output conditions indicated a 60% reduction in instantaneous power draw per fixture (from 150 W for HPS to ~60 W for LED). With adaptive dimming enabled, average power consumption further declined, as lights operated at 30–40% of peak output during late-night hours. Continuous logging over a four-week period confirmed that cumulative daily energy use per fixture dropped from an average of 1.8 kWh/day (HPS) to 0.6 kWh/day (LED). Photometric analyses revealed that the LED fixtures achieved superior illumination performance. Average road surface illuminance increased from 12 lx (HPS) to 18 lx (LED), and uniformity ratio improved from 0.3 to 0.5. Peak-to-valley contrast was reduced by 40%, minimizing glare and dark spots (Ashdown, 2014). The colour rendering index (CRI) of the LED system was measured at ~70, significantly higher than HPS lamps with CRI <25. These enhancements were confirmed through field testing and community surveys. Figure 2 shows the photometric comparison of street lighting before and after retrofit.

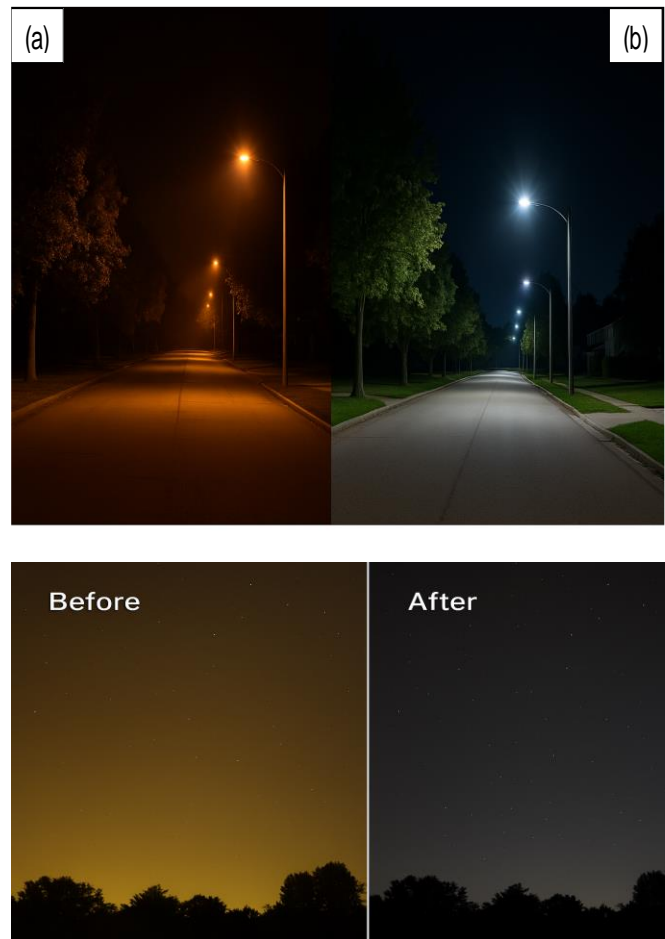

**Figure 2. Photometric comparison of street lighting before and after retrofit.**

**(a) High-pressure sodium (HPS) (b) LED installations**

Sensor-based dimming operated reliably under real-world conditions. PIR sensors detected motion up to 12 meters and triggered full brightness within approximately one second. Ambient light sensors enabled dimming during dawn/dusk transitions. Figure 3 illustrates typical motion-triggered response profiles, with rapid transitions and minimal false activations (~2%). Weather-responsive dimming during rainy conditions further demonstrated adaptive performance.

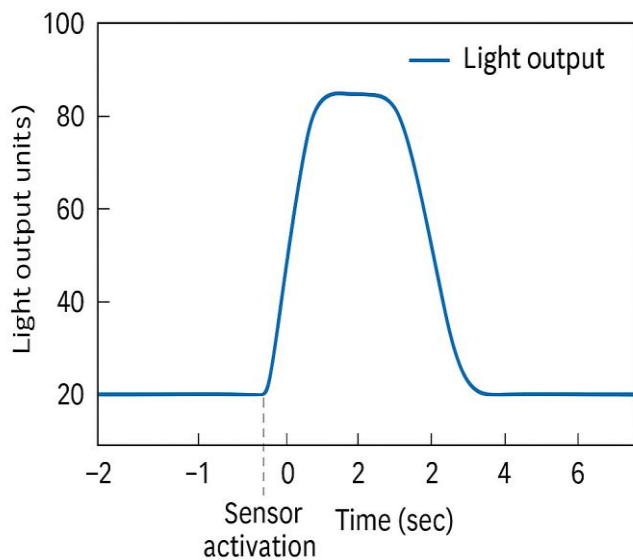

**Figure 3: Typical motion-triggered response profiles**

Thermal and electrical performance remained within design targets. Heat sink assemblies-maintained LED junction temperatures below 75 °C during typical nighttime operation (25–30 °C). Driver efficiency remained above 93% and power factor above 0.98 across variable loads (Zhang & Wang, 2017). No thermal failures or regulation faults were observed during the pilot. Environmental performance was also notable. Full-cutoff optics reduced upward light leakage, contributing to a 0.2 magnitude improvement in zenith sky brightness as measured by SQM photometers. Light trespass into adjacent properties decreased by 50–70%, promoting residential comfort and aligning with dark-sky goals. Remote diagnostics via the IoT backend revealed a 98% communication success rate. Logged data included energy usage, temperature, dimming state, and sensor activations. The system also detected three abnormal fixtures proactively, showing its potential for predictive maintenance. The sum of these results supports the proposition that intelligent LED systems offer substantial advantages compared to traditional lighting, and especially in terms of energy efficiency, environmental sustainability, as well as operational redundancy and scalability. The system's modular and networked design enables its integration into larger smart city initiatives for traffic monitoring, air quality measurement, and urban analytics. With other benefits like reduced maintenance and enhanced perception of safety, this approach presents an encouraging direction for sustainable urban lighting transformation.

#### IV. CONCLUSION

This paper illustrates the effective deployment and performance of an intelligent LED lighting system for promoting urban sustainability. Initial deployment manifested concrete energy savings, better illumination quality, and reduced environmental impacts relative to traditional high-pressure sodium systems. The application of adaptive dimming in conjunction with real-time sensor feedback

enabled dynamic lighting control to be optimized for energy consumption without compromising safety and visibility levels. The system's high degree of energy efficiency, thermal stability, and IoT-based monitoring capabilities also indicate its reliability and maintainability of operations.

The positive outcome of this pilot, supported by quantitative evaluations and community feedback, indicates that smart LED infrastructure can serve as a foundational component in the evolution of smart cities. Beyond reducing energy use and emissions, the system promotes environmental conservation by reducing light pollution and establishes a basis for possible integration with city data and services in the future. Since urban centers around the world face mounting pressures to modernize their infrastructure while also meeting climate targets, the findings of this study offer a compelling case for the blanket adoption of smart street lighting systems.

#### ACKNOWLEDGMENTS

The authors gratefully acknowledge the financial support provided by the Tertiary Education Trust Fund (TETFund) through the Institutional-Based Research (IBR) grant at The Federal Polytechnic Ukana. This fund was significant in supporting the research and making sure this study was conducted successfully.

#### REFERENCES

- Ashdown, I. (2014). LED Roadway Lighting – Uniformity and Glare. *Illuminating Engineering Society Conference*.
- Cervero, R., & Guerra, E. (2011). Urban Densities and Transit: A Multi-dimensional Perspective. *Institute of Urban and Regional Development*.
- Falchi, F., Cinzano, P., Duriscoe, D., Kyba, C. C. M., Elvidge, C. D., Baugh, K., ... & Furgoni, R. (2016). The new world atlas of artificial night sky brightness. *Science Advances*, 2(6), e1600377.
- Figueiro, M. G., & Rea, M. S. (2010). Lack of short-wavelength light during the school day delays dim light melatonin onset (DLMO) in middle school students. *Neuro Endocrinology Letters*, 31(1), 92–96.
- LA Bureau of Street Lighting. (n.d.). LED Streetlight Conversion Program. <https://bsl.lacity.org>
- Mohan, A., Krishnan, R., Arshinder, K., Vandore, J., & Ramanathan, U. (2023). Management of Postharvest Losses and Wastages in the Indian Tomato Supply Chain—A Temperature-Controlled Storage Perspective. *Sustainability*, 15(2), 469.
- Narendran, N., Gu, Y., Freyssonier, J. P., Yu, H., & Deng, L. (2015). Energy and economic evaluation of LED street lighting. *Lighting Research & Technology*, 47(6), 676–699.

Schudel, S., Shoji, K., Shrivastava, C., Onwude, D., & Defraeye, T. (2023). Solution roadmap to reduce food loss along your postharvest supply chain from farm to retail. *Food Packaging and Shelf Life*, 35, 101057.

Scientific Diagram. (n.d.). IoT-based smart street light Controller schematic diagram. [https://www.researchgate.net/figure/IOT-based-smart-street-light-controller-schematic-diagram\\_fig1\\_325438701](https://www.researchgate.net/figure/IOT-based-smart-street-light-controller-schematic-diagram_fig1_325438701).

Zhang, J., & Wang, Y. (2017). Thermal management of high-power LEDs with integrated heat sink and vapor chamber. *Applied Thermal Engineering*, 123, 469–478.